

Product leaflet

NOM 4

Oil mist filter for single CNC machines



NOM 4





- ✓ Low maintenance cost
- ✓ Self draining mist filter
- ✓ Easy to install
- ✓ High filtration efficiency
- ✓ Designed to fit into limited space

The NOM 4 is an oil mist filter in compact design and therefore suitable for enclosed cabinet single CNC machines. The unit is easy to install and enables maximum flexibility in the workshop, as it is normally installed on top of the machine. The NOM 4 is suitable for emulsion mist.

NOM 4

Certifications	CE
Noise level (dB(A))	66,1
Protection class	IP55
Filter efficiency (%)	97.5
Compressed air requirement	No
Compressed air consumption	No
Installation	Indoor
Material	Housing made in oil resistant wet painted sheet metal.
Suitable for combustible dust	False
Material recycling (%)	69
Filter Area (m ²)	3
Capacity (max airflow m ³ /h)	400
[ProductOperatingTemperature]	5 - 60 deg
Frequency (Hz)	50
Filter type	[cartridge]
Number of filter elements	1
Filter material	Glassfibre
Weight (kg)	29
Power (kW)	0,37

Models

	Item no	Power voltage (V)	No of phases	Amperage (A)
	12610368	230	1	3,15
	12610468 ^[1]	230	1	3,15
	12610568	400/230	3	1,0/1,75
	12610668 ^[1]	400/230	3	1,0/1,75

^[1] Includes HEPA filter with 8,5 sqm filterarea and with 99,97% efficiency.

Accessories

	Accessory	Item no
	Prefilter NOM 4 3m2	12373653
	HEPA 5,5m2 NOM 4	12373645
	Wall bracket.	10504035
	Drip tray NOM 4	12373657
	Machine stand NOM 4	12373705
	Pressure garge kit NOM 4	12373656

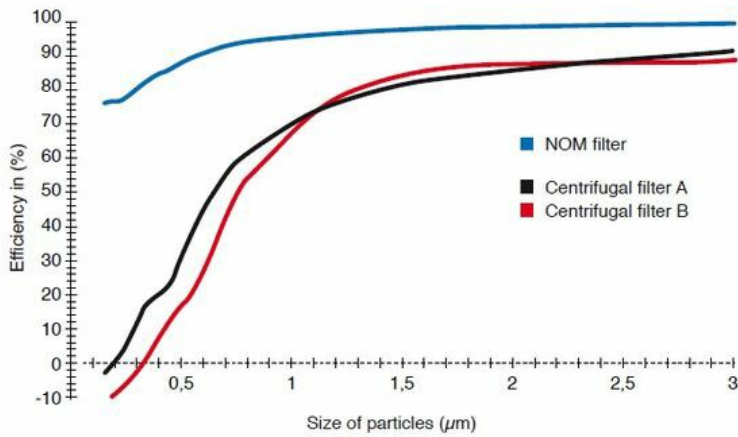
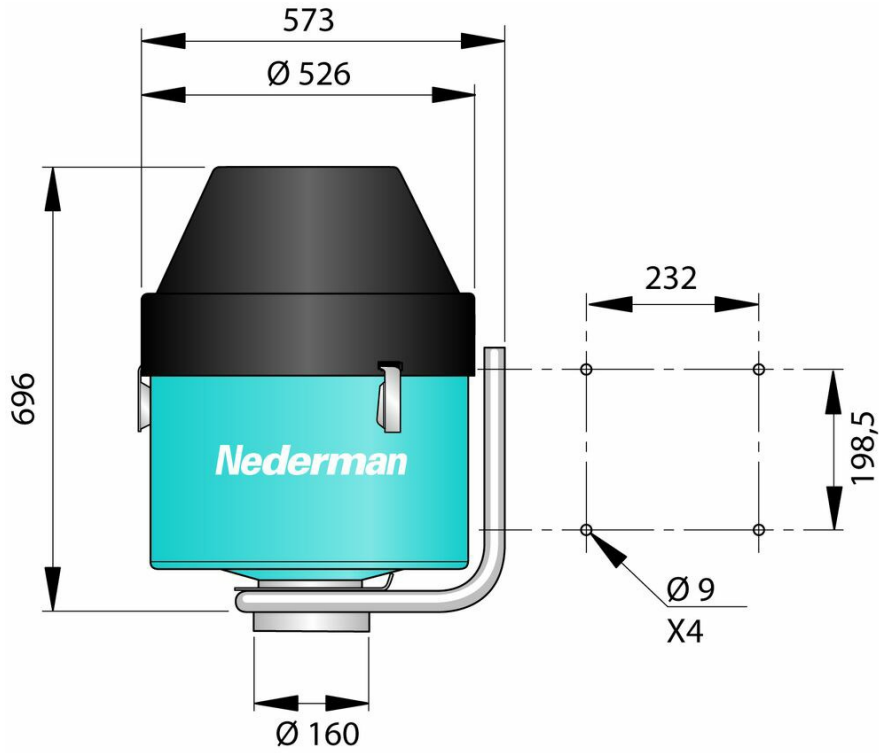

Efficiency of the mainfilter for NOM, compared with typical centrifugal filters, tested with DOP

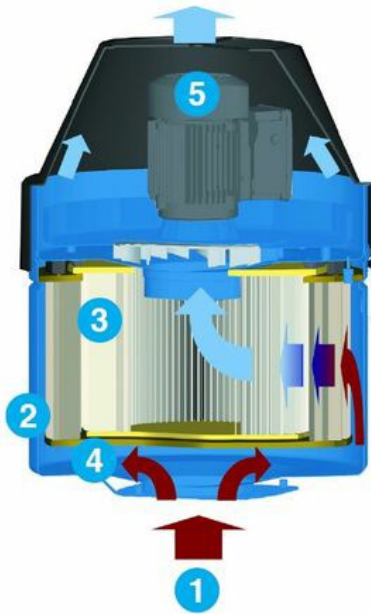

1. The contaminated air from the process is drawn into the lower chamber.
2. The pre-filter separates most of the largest particles and has a self-draining function, and therefore becomes saturated with oil which means that the filter can handle large amounts of emulsion. The pre-filter is washable. Filtration efficiency >97,5% for oilmist.
3. The HEPA filter meets the demands from authorities on efficient cleaning. All NOM filters can therefore be equipped with HEPA filter. The HEPA filter is not washable.
4. Return drainage pipe. The oil is drained back to a collecting tank or to the machine.
5. Integrated fan