

FilterBox 10A

Automatically cleaned for light to medium dust & fume applications.
W3 tested.



FilterBox 10A

- ✓ User friendly and superior filter cleaning, mechanical and/or with compressed air for long filter life
- ✓ Automatic damper preventing dust from leaking out while cleaning
- ✓ Dust free filter replacement and emptying of dust bin
- ✓ Third party approval for welding fumes category W3 according to EN 15012-1
- ✓ Filter efficiency M6 (EN779), MERV 11 (ASHRAE 52.2, 2017). Approved for welding fumes category W3 according to EN 15012-1, third party tested.+F5:F11

The FilterBox 10A is equipped with a N24 fan for a maximum air flow capacity of 1 000 m³/h (600 CFM). An integrated silencer reduces noise from the fan and outlet air.

The unit has an advanced filter control system with automatic cleaning that starts when the air flow is too low. Depending on the model, it is equipped with mechanical cleaning for dust applications or a combination of mechanical and compressed air cleaning for fumes and dust.

FilterBox 10A is available either as a mobile unit on wheels or attached to a floor stand. Additional protection from harmful particles is provided if a HEPA filter is installed.

For dust applications, the unit is cleaned mechanically. For welding fumes it uses a combination of mechanical and compressed air cleaning.

For welding applications, compressed air cleaning is required.

Note! FilterBox is not for use in environments where combustible dust or gases are present, and it is not for use in filtering combustible dust or gases.

FilterBox 10A

[ProductCertifications]	[ce]
[ProductNoiselevel]	66
[ProductProtectionclass]	IP 54
[ProductFilterefficiency]	99
[ProductInstallation]	[Indoor]
[ProductMaterial]	Casing in rotomoulded plastic
[ProductDustbinvolume]	15
[ProductExtractionArmdiameter]	160
[ProductAirflow]	1000
[ProductFilterArea]	13
[ItemFrequency]	50
[ItemFilterType]	[cartridge]
[ItemNbrofFilterElements]	1
[ItemElectricplug]	[without]
[ItemFilterCleaningMethod]	[Mechanical], [CompressedAir]
[ItemExtractionMethod]	extraction arm
[ItemFilterChangeIndication]	False
[ItemFumeAndDustApplication]	Light-Medium

This content is protected under copyright law, furnished for informational use only, and subject to change without notice. © Nederman Holding AB









2026-06-26

3/7

Nederman

FilterBox 10A

Models

	Item no	[ItemArmLength]	[ItemPowerVoltage]	[ItemNoofphases]	[ItemMounting]	[ItemWeight]	[ItemPower]	[ItemFilterArea]
	12655263	3	230	3	[mobile]	102	0,9	
	12655363	3	230	3	[floormounted]	99	0,9	
	12655463	3	400	3	[mobile]	102	0,9	13
	12655563	3	400	3	[floormounted]	99	0,9	
	12655663	3	230	1	[mobile]	102	0,75	
	12655763	3	230	1	[floormounted]	99	0,75	
	12655963	3	110	1	[floormounted]	99	0,75	
	12685063	Without	400	3	[floormounted]	99	0,9	
	12686763	Without	400	3	[mobile]	102	0,9	

This content is protected under copyright law, furnished for informational use only, and subject to change without notice. © Nederman Holding AB

2026-06-26













4/7

Nederman

FilterBox 10A

Accessories

Accessory	Item no
 Outlet with duct connection D=200mm	12376749

	Accessory	Item no
		
	Spotlight original, (LED) 24V, 5W	12376616
	Spark protection for Original hood and for NEX MD hood	10551335
	LED light/fan switch for Original hood. Including: LED 24V, cable, switch, socket, lens, screws, nuts, cable straps, spring	10376922
	Filter-PW-FB-13	12332672
	Filter-PW HE-FB-15	12371106
	Filter PWA-FB-15	12371412
	HEPA filter H13 10m2 Filterbox	12376615
	Bags for Filterbox dust bin, 10pcs	12376618
	HEPA filter H14 10m2 Filterbox	12376756
	Sensor clamp to be attached to the earth cable of the welding power source.	14372199
	Twin Module blue	12376801
	High efficiency Main Replacement filter for FilterBox. Nanofiber 17 m ² (183 ft ²). Compatible with all FilterBoxes with Pneumatic cleaning.	12377251

This content is protected under copyright law, furnished for informational use only, and subject to change without notice. © Nederman Holding AB

2026-06-26

5/7

Nederman

FilterBox 10A

Accessories

	Accessory	Item no
	FilterBox ePTFE High Efficiency Replacement filter. 13m ² (140 ft ²).	12377252

This content is protected under copyright law, furnished for informational use only, and subject to change without notice. © Nederman Holding AB

2026-06-26

6/7

Nederman

FilterBox 10A

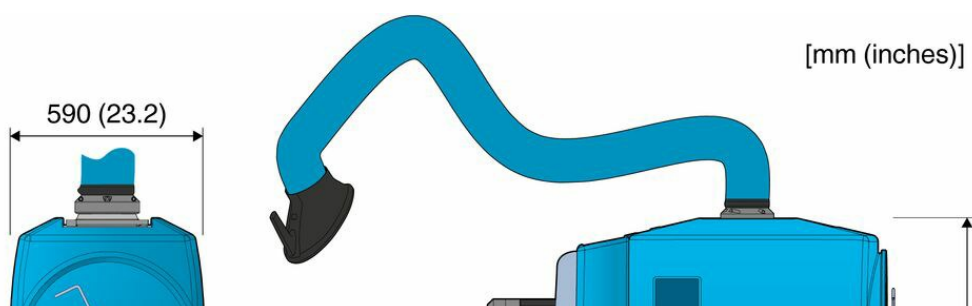

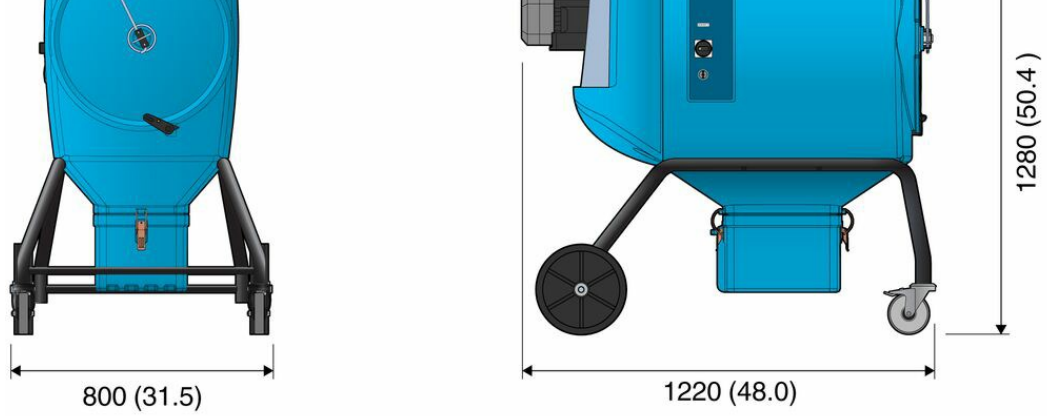

FilterBox 10A mobile

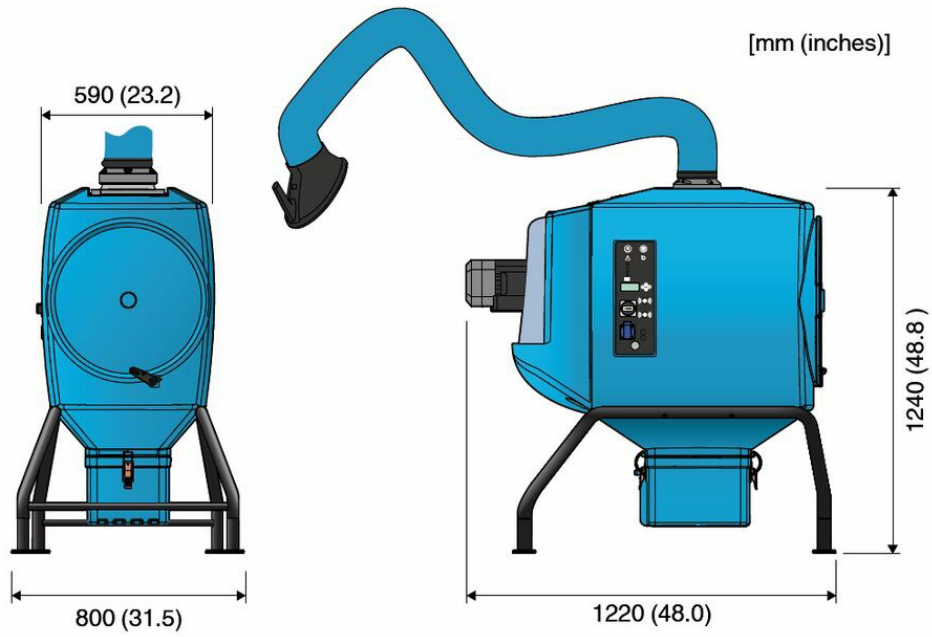

Floor mounted FilterBox 10A

FilterBox 10A Floor